

# OIL-INJECTED ROTARY SCREW COMPRESSORS

GX 2-7 EP  
G 7-15 EL

*Sustainable Productivity*

Atlas Copco





## **THE IDEAL SMALL BUSINESS COMPRESSOR**

Atlas Copco compressors are legendary for their reliability and efficiency. That is why our G-series has long been the preferred air solution for small and medium sized businesses. The GX 2-7 EP and the G 7-15 EL simply check all the boxes:

- Quiet
- Efficient
- Powerful
- Reliable

### **ATLAS COPCO, PREMIUM QUALITY SINCE 1873**

Atlas Copco was founded in 1873 and is based in Stockholm, Sweden. We have been a global leader in high-quality compressed air technology for more than a century and continue to raise the bar with innovative products.



## THE NEW G-SERIES

The latest-generation G-series comes with Atlas Copco's powerful rotary screw element and an advanced electronic controller on the G 7-15 EL to go above and beyond the call of duty.

### BUILT-IN RELIABILITY

- Atlas Copco's patented rotary screw element allows for a 100% duty cycle.
- The complete unit is designed to operate at ambient temperatures of up to 46 °C/115 °F.

### EASY INSTALLATION

- Available in multiple configurations – including floor or tank mounted and with or without integrated dryer.
- Extremely small footprint and cooling air discharge from the top allow for placement against a wall or even in a corner.

### ADVANCED MONITORING

The G 7-15 EL's new BASE controller offers advanced monitoring and control:

- Icon-based display, pressure settings, temperature reading.
- Running hours/hours working @ load.
- Service warnings.
- Outlet pressure setting directly on the controller.
- Pressure and element outlet temperature reading.

### ROBUST AND EFFICIENT COMPRESSION ELEMENT

Atlas Copco's trusted rotary screw element offers an increased free air delivery by up to 3% compared to the previous models.





## **ZERO HASSLE, ZERO WORRIES COMPRESSORS**



### **HIGH RELIABILITY**

- 100% continuous duty cycle.
- Up to 46 °C/115 °F ambient temperatures.



### **LOW MAINTENANCE**

- Easy access for maintenance.
- Quality components.



### **SILENT OPERATION**

- Belt-driven element.
- Reduced noise levels and low vibration.



### **FULL FEATURE (FF)**

- Integrated refrigerant air dryer.
- In-line PD/DD air filters.



### **ENVIRONMENTALLY FRIENDLY**

- Reduced energy consumption.
- Low CO<sub>2</sub> emissions.

**ATLAS COPCO  
G-SERIES  
—  
A TRUSTED  
PARTNER**



## G 7-15 EL

### INDUSTRY-LEADING PERFORMANCE

- Thanks to load/no load control, the compressor controller switches automatically to the optimum control mode for high, low and intermittent air consumption.
- Best-in-class performance, total reliability and low power consumption.



## GX 2-7 EP

### COMPACT AND EFFICIENT

- Compared to piston compressors, the GX offers reduced energy consumption and high efficiency.
- The rotary screw technology minimizes vibrations for silent operation at the lowest initial investment.
- The standard start/stop control on the GX 2-5 EP ensures the compressor only consumes power when compressed air is needed. The GX 7 EP is equipped with energy efficient load/no load control.

# QUALITY AIR PERFORMANCE

Untreated compressed air contains moisture, aerosols and dirt particles that can damage your system and contaminate your end product. Atlas Copco's G-series compressors provide the clean, dry air that improves reliability, avoids costly downtime and safeguards your products.

## FULL FEATURE WITH BUILT-IN DRYER

The Full Feature version comes with a built-in refrigerant air dryer. It cools the compressed air and removes any moisture before it can enter your compressed air network. This prevents rust in your compressed air piping and avoids damage to your air tools.

## A CHOICE OF FILTERS

To ensure your compressed air meets the quality air needs of a wide range of applications, different grade PD/DD air filters can be selected.

## TYPICAL FLOW CHART FOR THE G 7-15 EL FF

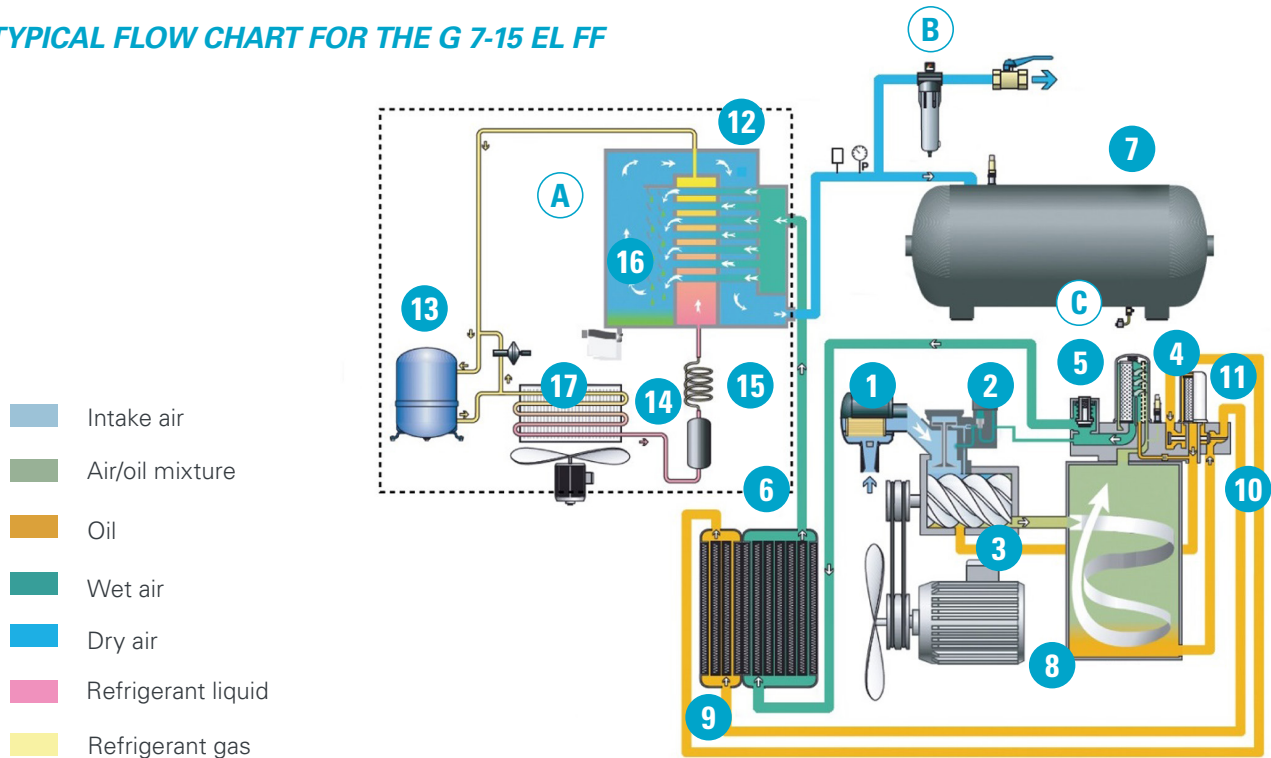

### AIR FLOW

- 1 Inlet air filter
- 2 Inlet valve
- 3 Compression element
- 4 Oil separator element
- 5 Minimum pressure valve
- 6 Aftercooler
- 7 Air receiver

### OIL FLOW

- 8 Oil reservoir
- 9 Oil cooler
- 10 Thermostatic valve block
- 11 Oil filter

### REFRIGERANT FLOW

- 12 Evaporator
- 13 Refrigerant compressor
- 14 Condenser
- 15 Capillary tube
- 16 Water separator
- 17 Electronic automatic drain

### OPTIONS

- A Full Feature
- B PD high efficiency air filter
- C Electronic receiver drain

# TECHNICAL SPECIFICATIONS

Compressor type	Maximum working pressure		Capacity FAD			Installed motor power		Noise level	Weight (kg/lbs)*	
	bar(e)	psi	l/s	m³/h	cfm	kW	hp	dB(A)	Pack	Full Feature
<b>50 Hz VERSION</b>										
GX 2 EP	10	145	4.0	14.4	8.5	2.2	3	61	165/364	200/441
GX 3 EP	10	145	5.3	19.1	11.2	3	4	61	165/364	200/441
GX 4 EP	10	145	7.8	28.1	16.5	4	5	62	165/364	200/441
GX 5 EP	10	145	10.0	36.0	21.2	5.5	7.5	64	165/364	200/441
GX 7 EP	10	145	14.0	50.4	29.7	7.5	10	66	214/472	264/582
G 7 EL	7.5	109	20.7	74.6	43.9	7.5	10	65	245/540	314/692
	10	145	18.0	64.9	38.2	7.5	10	65	245/540	314/692
G 11 EL	13	189	13.9	50.1	29.5	7.5	10	65	245/540	314/692
	7.5	109	28.7	103.3	60.8	11	15	67	257/567	326/719
	10	145	24.0	86.5	50.9	11	15	67	257/567	326/719
G 15 EL	13	189	19.2	69.1	40.7	11	15	67	257/567	326/719
	7.5	109	32.4	116.7	68.7	15	20	71	276/594	338/746
	10	145	29.1	104.8	61.7	15	20	71	276/594	338/746
	13	189	22.8	82.1	48.3	15	20	71	276/594	338/746
<b>60 Hz VERSION</b>										
GX 2 EP	10.3	150	4.0	14.4	8.5	2.2	3	61	165/364	200/441
GX 4 EP	10.3	150	7.8	28.1	16.5	4	5	62	165/364	200/441
GX 5 EP	10.3	150	10.0	36.0	21.2	5.5	7.5	64	165/364	200/441
GX 7 EP	10.3	150	13.8	49.6	29.2	7.5	10	66	214/472	264/582
G 7 EL	7.4	107	21.2	76.3	44.9	7.5	10	67	245/540	314/692
	9.1	132	18.7	67.3	39.6	7.5	10	67	245/540	314/692
	10.8	157	16.4	59.1	34.8	7.5	10	67	245/540	314/692
	12.5	181	13.8	49.8	29.3	7.5	10	67	245/540	314/692
G 11 EL	7.4	107	28.1	101.3	59.6	11	15	68	257/567	326/719
	9.1	132	25.4	91.4	53.8	11	15	68	257/567	326/719
	10.8	157	23.0	82.9	48.8	11	15	68	257/567	326/719
G 15 EL	12.5	181	11.7	42.1	24.8	11	15	68	257/567	326/719
	7.4	107	33.1	119.3	70.2	15	20	71	276/594	338/746
	9.1	132	29.6	106.7	62.8	15	20	71	276/594	338/746
	10.8	157	27.3	98.4	57.9	15	20	71	276/594	338/746
	12.5	181	23.1	83.3	49.0	15	20	71	276/594	338/746

\*Tank mounted variant.

EP: Electropneumatic, EL: BASE controller.

Standard air receiver size, GX 2-7 EP: 200 l/60 gal, G 7-15 EL: 270 l/80 gal.

Unit performance measured according to ISO 1217, latest edition.

Mean noise level (pack variant) measured according to Pneurop/Cagi PN8NTC2 test code; tolerance 3 dB(A).

## OPTIONS

Available options	GX 2-7 EP	GX 2-7 EP FF	G 7-15 EL	G 7-15 EL FF
Integrated aftercooler	-	-	○	✓
Water separator (shipped loose)	-	✓	○	✓
Timer water drain on water separator (shipped loose)	-	-	○	-
Timer drain on air receiver (tank mounted only)	○	○	○	○
Electronic no loss water drain on water separator (shipped loose)	-	✓	○	✓
Electronic no loss water drain on air receiver (500 l/120 gal tank mounted only)	○	○	○	○
Integrated DD filter kit	-	-	-	○
Integrated high performance PD filter kit	-	○	-	○
500 l/120 gal air receiver (tank mounted only)	-	-	○	○
Tropical thermostat	-	-	○	○

✓ Standard

○ Optional

- Not available

## DIMENSIONS

	L (mm)	W (mm)	H (mm)
<b>PACK FLOOR MOUNTED</b>			
GX 2-7 EP	620	575/605*	975
G 7-15 EL	810/840*	590	1085
<b>FULL FEATURE FLOOR MOUNTED</b>			
GX 2-7 EP	-	-	-
G 7-15 EL	1205/1235*	590	1085
<b>PACK TANK MOUNTED</b>			
GX 2-7 EP	1420	575	1280
G 7-15 EL	1533	590	1332
<b>FULL FEATURE TANK MOUNTED</b>			
GX 2-7 EP	1420	575	1280
G 7-15 EL	1533	590	1332

\* Length with inlet grating.

\*\* Dimensions of G 7-15 EL tank mounted are 1935 x 590 x 1463 mm (L x W x H) with a 500 l vessel and 1880 x 590 x 1463 mm (L x W x H) with a 120 gal vessel.

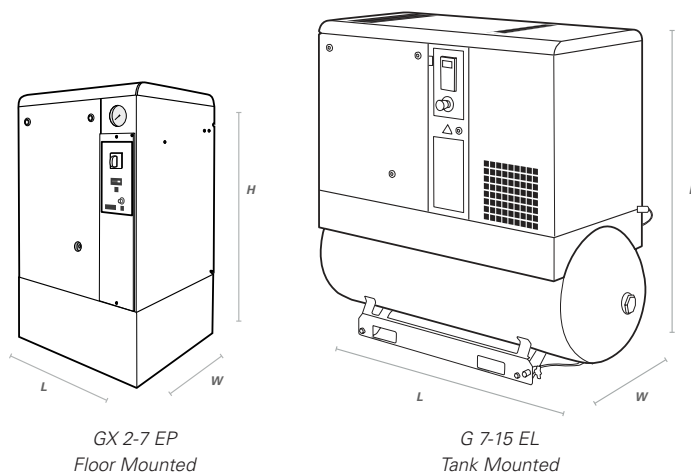

## ***COMMITTED TO SUSTAINABLE PRODUCTIVITY***

We stand by our responsibilities towards our customers, towards the environment and the people around us. We make performance stand the test of time. This is what we call – Sustainable Productivity.



2935 0869 49 © 2016, Atlas Copco Airpower NV, Belgium. All rights reserved.  
Designs and specifications are subject to change without notice or obligation.  
Read all safety instructions in the manual before usage.

***Atlas Copco***